



GYL-20400
Top Guided Type Cut-off
Control Valve

ZHEJIANG BEIER CONTROL VALVE CO.,LTD.
[Http://www.Controlvalves.cn](http://www.Controlvalves.cn)

High Quality Guide Style Control Valves

Top Guided Cut-off Control Valves

The heavy load, used in the normal and bad conditions of operating mode, closed strictly, adapt to control each kind of the fluid and gas which are needed cut off. The adaption temperature range is $-196\sim+538^{\circ}\text{C}$ (If you choose soft seat, the adaption temperature is $-45\sim+200^{\circ}\text{C}$).

The Straight Stroke Control Valves, which is suitable for the entail of sorts of operating mode to design, and Inside-component part of the Valve can interchangeable. Different kinds of the Inside component modular is satisfied with the varieties of manufacturing process which called upon.

The BEIER product widely uses in each kind of harsh operating mode.

BEIER Yours succeed partner.

The long service life, maintains conveniently.

GYL-20400 SERIES CONTROL VALVES

Trim type: Cut-off type
Top guided unbalance trim
Cage pressure active seat plug
Cut-off structure
Body type: Selection of Control Valve Model See Page 14
Size range: 1" ~ 12"

Pressure level range: CLASS 150~600#
Standard close level: CLASS V (Standard type, metal seat)
CLASS VI (Optional type, soft seat)

Application situation: Heavy loaded, it can be used to normal or very heavy duty services, tight closed, to control each fluids or gas. Suitable temperature range is $-196\sim+538^{\circ}\text{C}$ (by soft seat, the suitable temperature is $-45\sim+200^{\circ}\text{C}$.)

Top guided single seat cut-off valve

Fig. 1

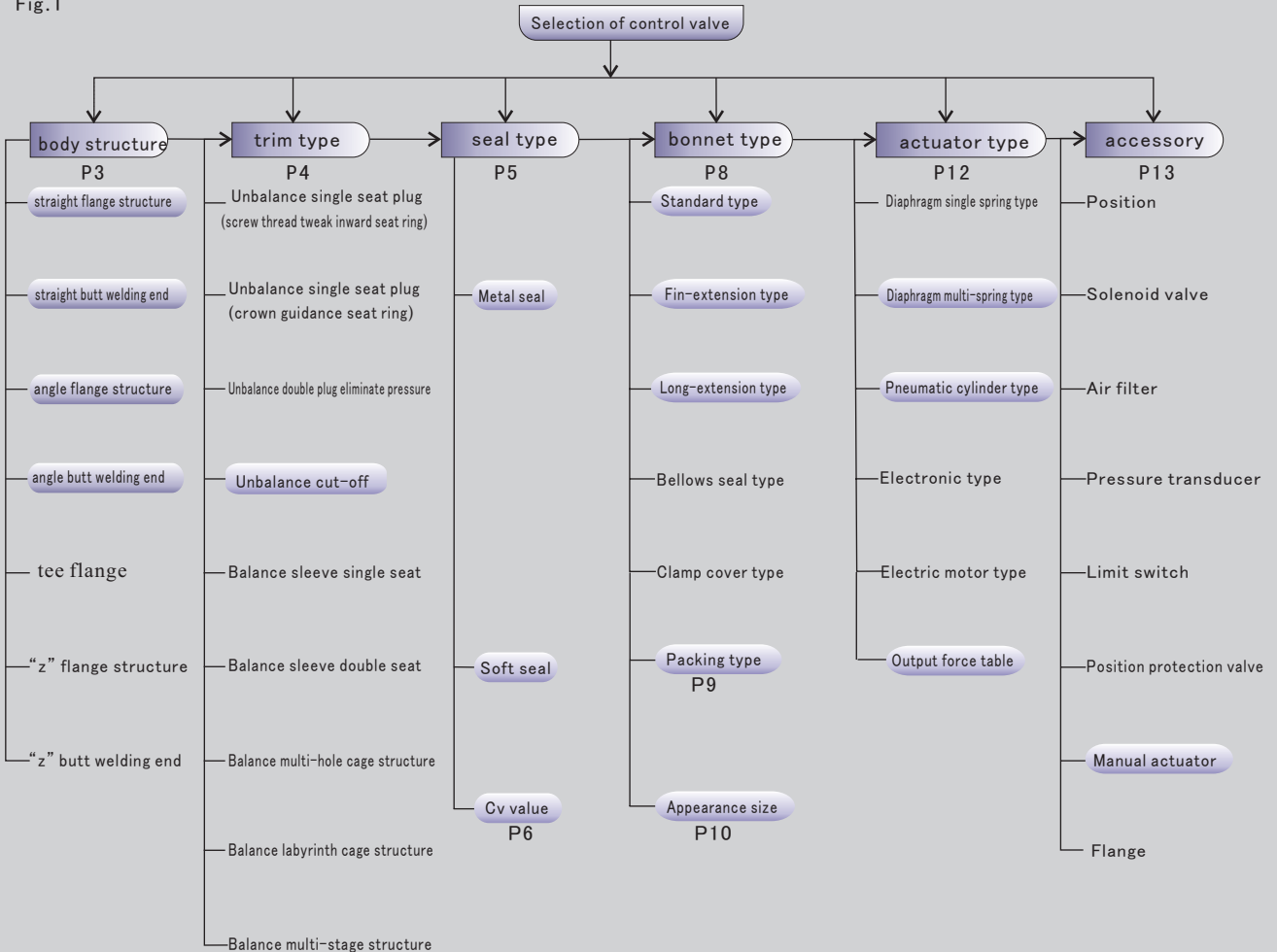

※ Note:

You may configure the GYL-20400 series valve according to the arrow to show by the Fig.1 of guidance chart.

The shadowed content is addressed in this manual.

Please see the corresponding page for the content you concern.

Some parts such as bonnet, actuator and accessory component are optional according to different operation conditions and specific requirements of customers, please consult BEIER engineers for detailed parameters.

The max pressure difference allowed when configuring actuators for control valves is not listed in this manual, and if necessary, please consult your BEIER engineers or calculate it with the control valve software of BEIER.

GYL-20400 Body structure

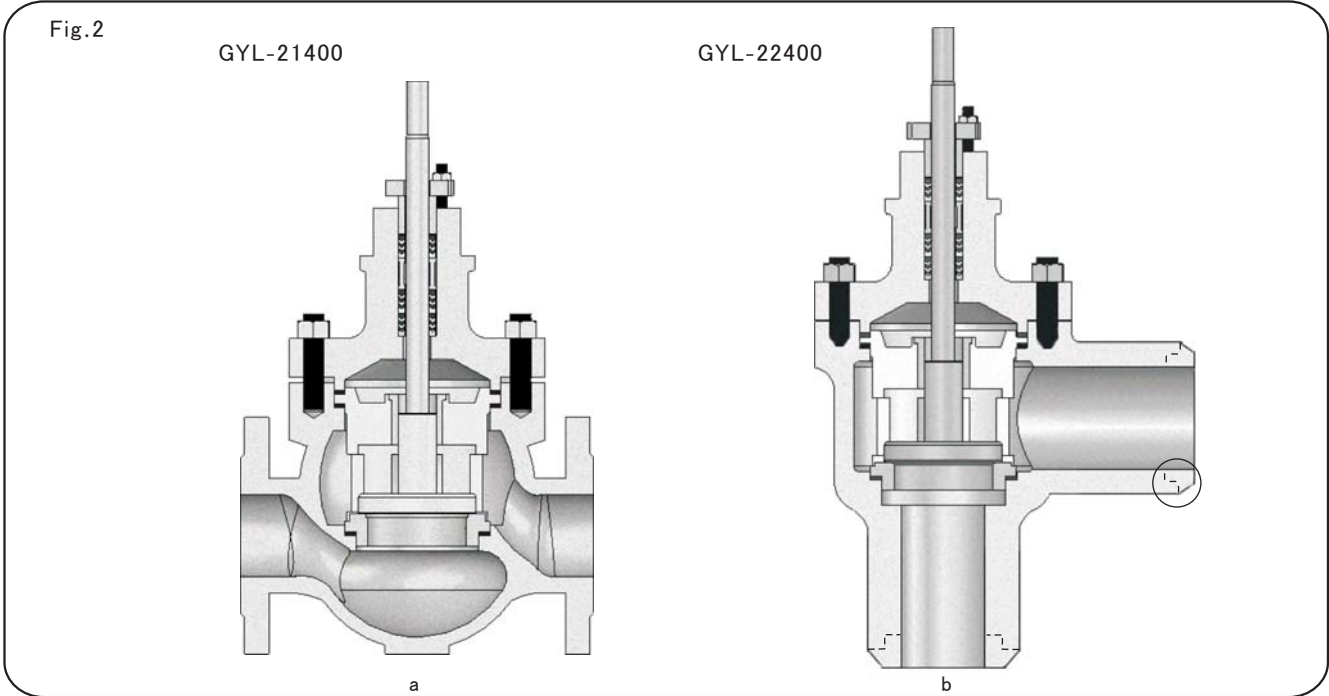

◆ A pneumatic diaphragm cut-off valve is composed of a pneumatic membrane actuator and a cut-off valve. It employs compressed air as the power and receives electric signals (or air signals) from the control system to enable 2-bit control for valves through directional control of solenoid valves. This sort of valves features a simple structure, reliable action, good sealing characteristics, a small flow resistance factor, a long lifecycle and easy installation etc. which is extensively applied in petrol, chemical, metallurgy, pharmacy, paper making and printing industries.

◆ Flange connection standard
 Flange: JB/T 79.1-94~JB/T 79.4-94
 Butt welding end: GB/T 9124-2000

◆ Type L-20400 Quick-opening Cage Cut-off Valve employs top-guided unbalanced high-strength heavy-load quick-opening spools, featuring an S-shape streamline channel which reduces pressure loss and increases flux. This type of control valves applies to the condition of heavy load, regular or poor operation conditions, as well as cut-off control for liquid or air under various pressures and temperatures because of good sealing characteristics. It is compatible with all kinds of actuators to offer switch control. In addition, its internal components are interchangeable with those of Type L-20000 and L-40000.

◆ The valve body in Fig. 2 (a) chart is the flange type; the circle of the (b) chart is butt welding type flange, and the part of dashed line is socket welding flange type.

Table. 1

Serial number	Part name	Material	Temperature range (°C)
1	Body	A216-WCB	-5~425
		A351-CF8	-196~538
		A351-CF8M	-196~538
		LF6	-196~-45
2	Bonnet	A216-WCB	-5~425
		A351-CF8	-196~538
		A351-CF8M	-196~538

GYL-20400 Trim type

Fig.3

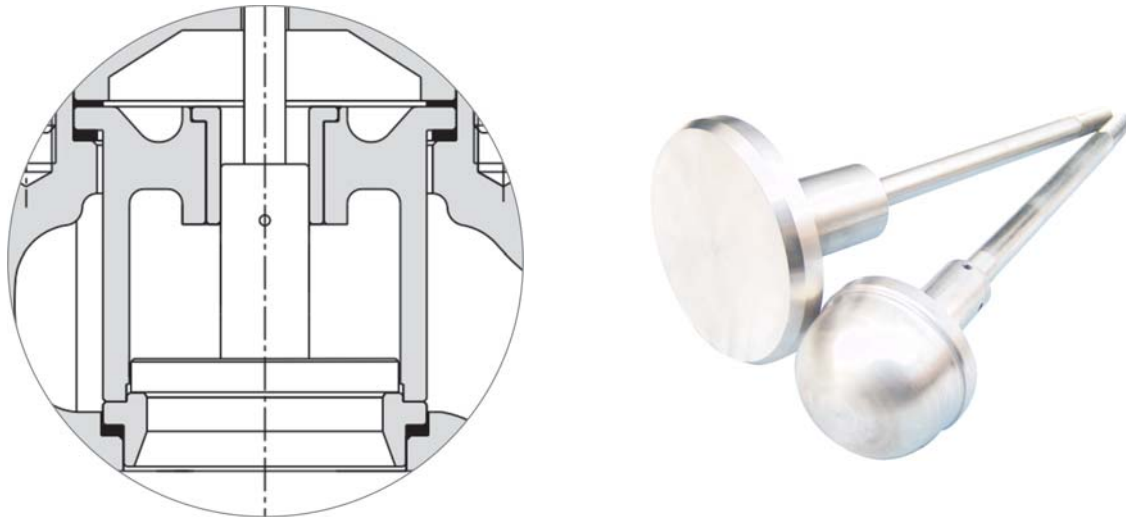

The Fig.3 (a) chart is the trim, b chart is the photo of plug.

GYL-20400 trim type

- ◆ High intensity, heavy loaded, top guided unbalance plug type
- ◆ The straight pressure type valve seat
- ◆ Quick-opening movement structure cut-off type plug

Table. 2

Part name	Material	Temperature range (°C)
Seat	A351-CF8M	-196~538
	A351-CF8M+Stellite seat	-196~538
	A351-CF8M+reinforced Teflon	-45~200
Plug	A351-CF8M	-196~538
	A351-CF8M+Stellite seat	-196~538
Cage	A216-WCB	-5~425
	17-4PH	-40~425
	A351-CF8	-196~538
Guided set	17-4PHSS Heat treatment	-40~425
	A351-CF8M+Stellite seat	-196~538
Stem	17-4PHSS Heat treatment	-40~425
	A351-CF8M+Hard chrome plated	-196~538
Gasket	Spiral wound stainless steel graphite	-196~538

GYL-20400 Valve seal type

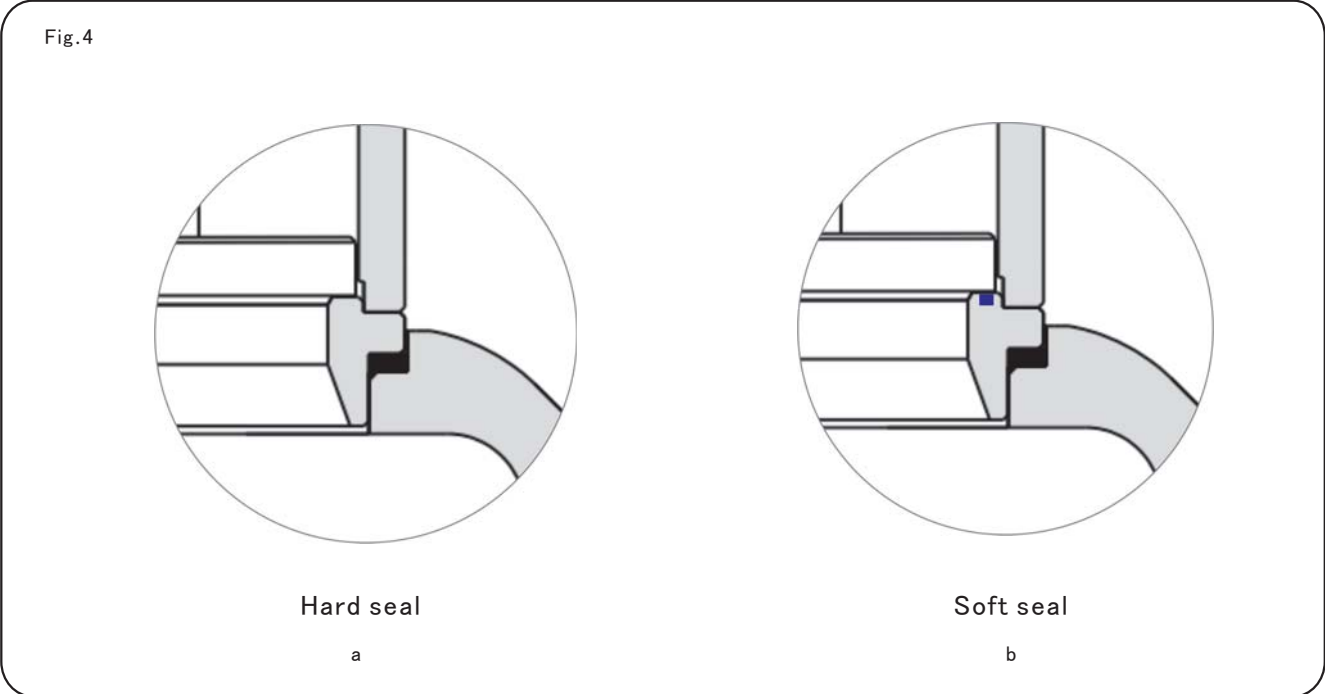

◆ **Hard seal:** The standard disposition seal structure, adapts each kind of operating mode fluid, has the strong vibration-proof performance characteristic, the valve seat closure performance conforms to ISO in the standard.

◆ **Soft seal:** Integer type seat soft seal structure, has high performance on seal ability, can resist causticity. In the chart the blue color partially for strengthen PTFE soft seat.

Table. 3

Part name	common pressure material	high pressure material
Plug	A351-CF8M	YG6、X、YG8 Quench-hardening steel filter chrome 1Gr18Ni9Ti, Cr18Ni12Mo2Ti Bead weld of cobalt chromium tungsten alloy
	A351-CF8M Nitriding	
Seat	A351-CF8M	2Gr13,Quench-hardening steel
	A351-CF8M Nitriding and strengthen PTFE	

◆ When fluid is with entrained particles, or overstep operating range and pressure range, please select satellite seat or stellite full surface, when the leakage grade is required be high, please select soft seat.

Cv value

Table. 4

Body size inch(mm)	Cage size inch	Maximal travel (mm)	Rating Cv value									
			Equal percentage characteristic					Linear characteristic				
			10	30	50	80	100	10	30	50	70	100
3/4(20)	1/4	16	0.09	0.17	0.34	0.95	0.4	0.27	0.68	1.09	1.49	2.1
	3/8		0.14	0.27	0.53	1.48	1.9	0.42	1.06	1.69	2.32	3.27
	1/2		0.22	0.43	0.85	2.37	2.92	0.67	1.66	2.65	3.65	5.13
	3/4		0.34	0.68	1.35	3.74	7.35	1.05	2.6	4.16	5.72	8.05
1(25)	3/8	16	0.14	0.27	0.53	1.48	1.9	0.42	1.06	1.69	2.32	3.27
	1/2		0.22	0.43	0.85	2.37	2.92	0.67	1.66	2.56	3.65	5.13
	3/4		0.34	0.68	1.35	3.74	7.35	1.05	2.6	4.16	5.72	8.05
	1		0.55	1.08	2.14	5.93	11.67	1.67	4.15	6.64	9.11	12.84
1-1/2(40)	1	25	0.55	1.08	2.14	5.93	11.67	1.67	4.15	6.64	9.11	12.84
	1-1/4		0.87	1.73	3.42	9.49	18.67	2.67	6.63	10.62	14.58	20.54
	1-1/2		1.36	2.72	5.35	14.82	29.17	4.17	10.37	16.59	22.79	32.09
2(50)	1-1/4	25	0.87	1.73	3.42	9.49	18.67	2.67	6.63	10.62	14.58	20.54
	1-1/2		1.36	2.72	5.35	14.82	29.17	4.17	10.37	16.59	22.79	32.09
	2		2.18	4.32	8.54	23.71	46.68	6.67	16.58	26.56	36.46	51.35
2-1/2(65)	1-1/2	40	1.36	2.72	5.35	14.92	29.17	4.17	10.37	16.59	22.79	32.09
	2		2.18	4.32	8.54	23.71	46.68	6.67	16.58	26.56	36.46	51.35
	2-1/2		3.34	6.81	13.5	37.35	73.52	10.47	20.01	41.63	57.17	80.52
3(80)	2	40	2.18	4.32	8.54	23.71	46.68	6.67	16.58	26.56	36.46	51.35
	2-1/2		3.34	6.81	13.5	37.35	73.52	10.47	26.01	41.63	57.17	80.52
	3		5.45	10.81	21.4	59.28	116.7	16.69	41.46	66.37	91.14	128.4
4(100)	2-1/2	40	3.34	6.81	13.5	37.35	73.52	10.47	26.01	41.63	57.17	80.52
	3		5.45	10.81	21.4	59.28	116.7	16.69	41.46	66.37	91.14	128.4
	4		8.72	17.29	34.2	94.85	186.7	26.7	66.34	106.2	145.8	205.4
5(125)	3	60	5.45	10.81	21.4	59.28	116.7	16.69	41.46	66.37	91.14	128.4
	4		8.72	17.29	34.2	94.85	186.7	26.7	66.34	106.2	145.8	205.4
	5		13.62	27.06	53.4	148.2	291.7	41.72	103.7	165.9	227.9	320.9
6(150)	4	60	8.72	17.29	34.2	94.85	186.7	26.7	66.34	106.2	145.8	205.4
	5		13.62	27.06	53.4	148.2	291.7	41.72	103.7	165.9	227.9	320.9
	6		21.8	43.23	85.4	237.1	466.8	66.75	165.9	265.5	364.6	513.5
8(200)	5	60	13.62	27.06	53.4	148.2	291.7	71.72	103.7	165.9	227.9	320.9
	6		21.8	43.23	85.4	237.1	466.8	66.75	165.9	265.5	364.6	513.5
	8		34.34	68.08	135	373.5	735.2	104.7	260.1	416.3	571.7	805.2
10(250)	10	60	45.9	91.3	181	504	1000	144	356	569	783	1102
12(300)	12	60	70.8	140.5	279	774	1521	220	543	868	1194	1680

- ◆ The Cv definition: when the valve all opens, with the 40-60° F water, keep valve beginnings and ends differential pressure is 1 psi, under this condition has flowed the flux(unit: gallon) of the water per minute. (A gallon is a unit of measure for liquid. 1 US gallon=3.785 liter)
- ◆ The conversion of Kv and Cv as follows: $Cv = 1.167 Kv$
- ◆ The Cv value in the actual operating mode compare with the graph have $\pm 5\%$ undulation in the specific traveling.

- ◆ BEIER company can provide the products which nominal diameter is bigger, please consult BEIER engineers for detailed Cv value.
- ◆ The trim of control valve In the graph is standard specification, and if needs to satisfy the special flow rate in the technics process, please consult your BEIER engineers.

Flow characteristic curve

Fig.5

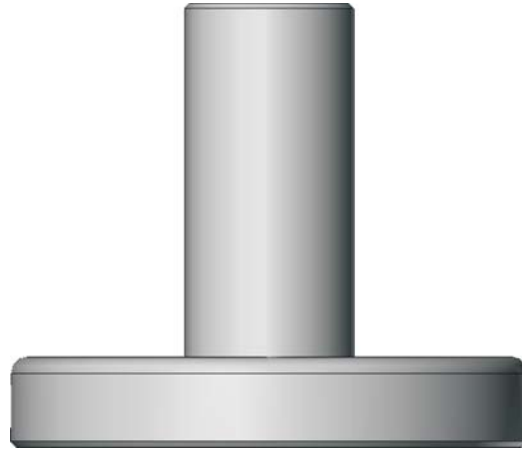

Quick-opening characteristic plug

◆ **Quick-opening characteristic Curve**

The flow characteristic when in small Cv working has big flow, along with opens to increase, the flow rate will achieve to maximum, hereafter increases, the change of flow rate is very small, therefore called quick-opening characteristic.

The plug of quick-opening type is a dull shape, like the Fig.5 chart shows, generally, its effective displacement generally for 1/4 of the valve seat diameter, when displacement increase again, the valve circulation area no longer increase, and lose the control action. Quick-opening characteristic shut-off valve is suitable for the fast to open or shut and the pair of position governing system.

Table.5

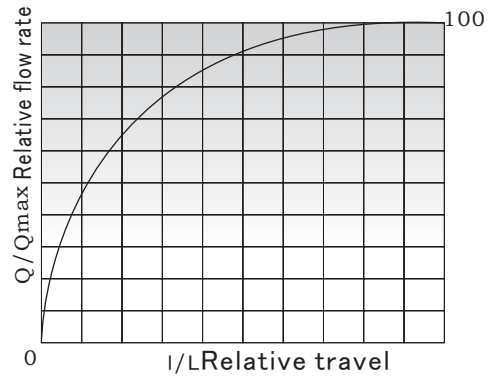

Quick-opening ideal flow rate characteristic

GYL-20400 Bonnet type

Fig. 6

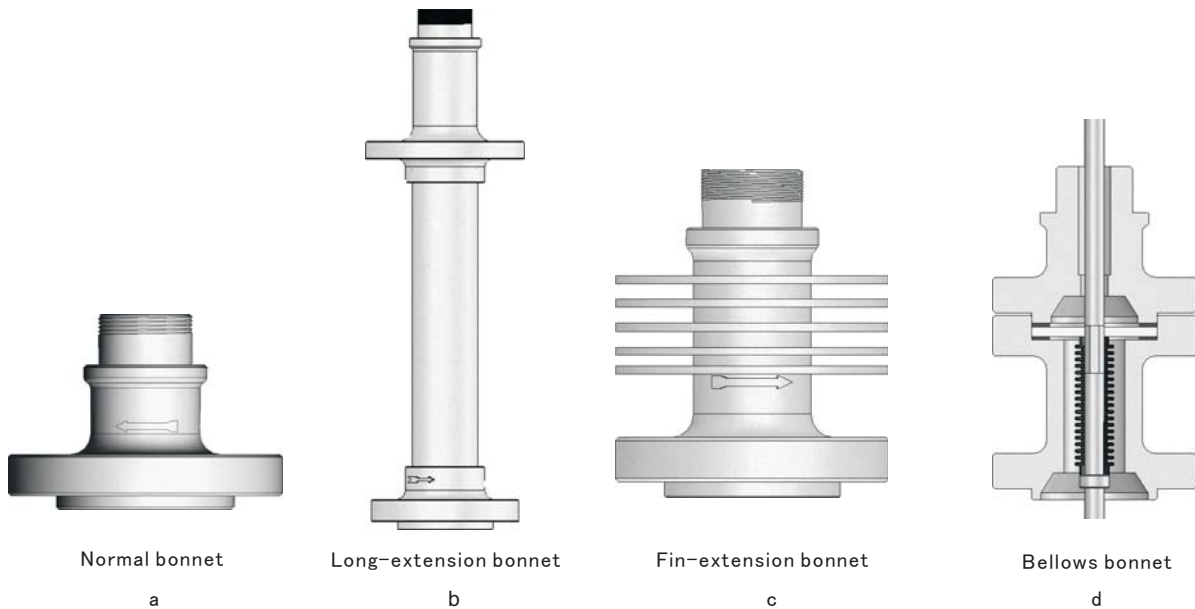

◆ Normal bonnet

Fig.6.a chart is a normal bonnet standard type, can seal the body and connect to actuator, which suitable temperature range is $-20\sim 230^{\circ}\text{C}$.

◆ Long-extension bonnet

Fig.6.b chart is a long-extension bonnet type, design for cryogenic service, which suitable temperature is $-196\sim 538^{\circ}\text{C}$, according to the different of the valve size, the strengthen range is $400\text{mm}\sim 900\text{mm}$, this kind bonnet can protect the packing and actuator effectively, adopts the low temperature material which can bear impact and suitable for different temperature requirement.

◆ Fin-extension bonnet

Fig.6.c chart is a fin-extension bonnet type, design for high temperature service, chooses special material, the maximum temperature can bear 750°C .

◆ Bellows bonnet

Fig.6.d chart is a bellows bonnet type, which is used the situation that not allow the any leakage around the stem, when the fluid is flammable, virulent, easy to explode, radioactive, precious or fast to damage the padding, generally speaking, we'll choose bellows bonnet type, and it also uses in under the vacuum to prevent leakage.

GYL-20400 Packing type

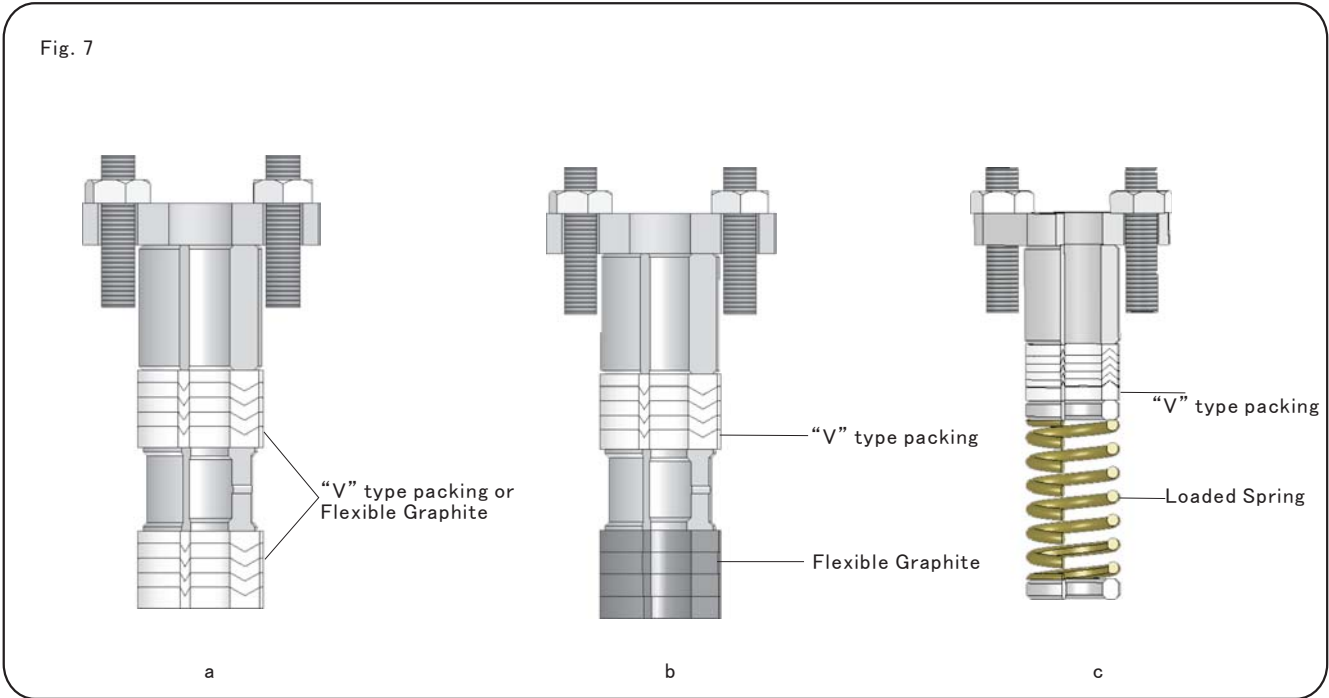

◆ packing module design

According to different of medium type and pressure, BEIER engineer will choose the suitable packing module to insure no leakage around the stem.

Fig.7.chart is a three different packing module design,
 (a) chart is a single design of "V" type packing or flexible graphite packing,
 (b) chart is a module design of "V" type packing or flexible graphite packing,
 (c) chart is a module design of "V" type packing and spring. The packing module design can solve the bad self-lubrication and leakage outside effectively.

◆ PTFE "V" type packing:have good lubricating and anti-corrosion ability,the physical and chemistry performance is stable, is one kind of good packing materials, the shortcoming is can't bear high temperature above 200 °C and used for alkaline metal in fusing state as well as high temperature medium like fluorine, hydrogen fluoride.

◆ Graphite ring material:

The graphite padding is one kind of new padding, This sort of paddings features a good sealing characteristics, lubricating ability, strong chemistry inert, anti-corrosive, and can bear the high or low temperature (-200~600 °C),etc, while the shortcoming is cannot use in the strong oxidizer.

Table. 7

PTFE packing

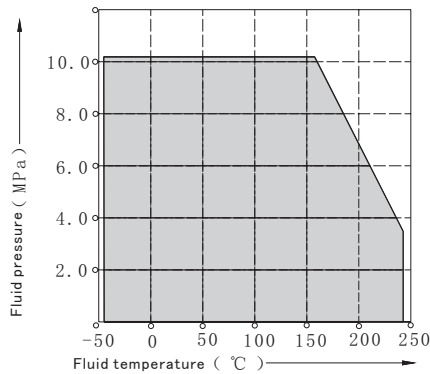

Flexible Graphite

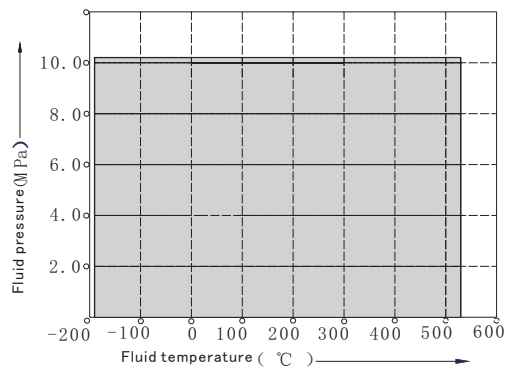

GYL-20400 Body size

Fig. 8

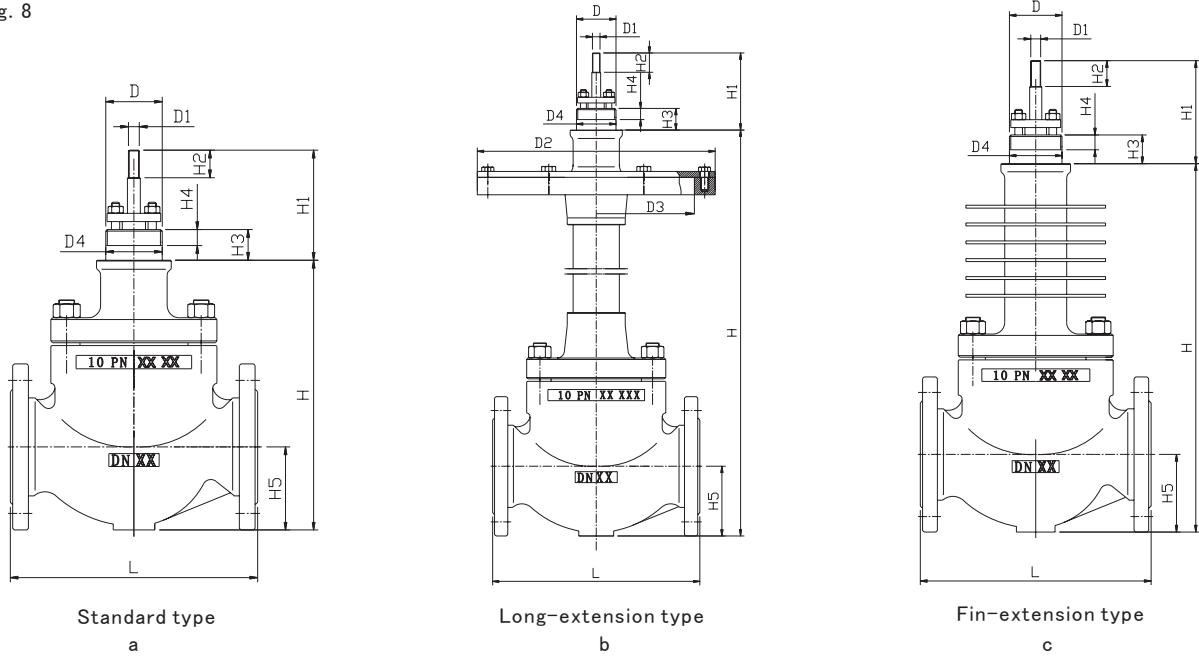

Table. 8

Valve flange execution standard: JB/T79.1-94~JB/T79.4-94

Body size	L			H								D	D1	D2	D3	D4		
	ANSI150P N1.6 JIS10K	ANSI300P N4.0 JIS30K	ANSI600P N6.4 JIS40K	Standard type	Fin- extension type	Long- extension type L=800	H1	H2	H3	H4	H5							
20(3/4)	184	194	206	184	334	852	130	40	34	15	52	M56	2	M12	1.25	φ290	φ235	φ56
25(1)	184	197	210	184	334	852	130	40	34	15	52	M56	2	M12	1.25	φ290	φ235	φ56
40(3/2)	222	235	251	238	407	868	130	40	34	15	68	M56	2	M12	1.25	φ335	φ280	φ56
50(2)	254	267	286	262	432	883	130	40	34	15	83	M56	2	M12	1.25	φ370	φ310	φ56
65(5/2)	276	292	311	307	507	893	130	45	37	15	93	M68	2	M16	1.5	φ410	φ340	φ68
80(3)	298	317	337	319	519	898	130	45	37	15	98	M68	2	M16	1.5	φ440	φ370	φ68
100(4)	352	368	394	351	551	917	130	45	37	15	117	M68	2	M16	1.5	φ490	φ420	φ68
125(5)	403	425	460	403	660	933	160	50	48	25	133	M80	2	M20	1.5	φ560	φ485	φ80
150(6)	451	473	508	444	704	950	160	50	48	25	150	M80	2	M20	1.5	φ630	φ550	φ80
200(8)	543	568	610	517	777	986	160	50	48	28	186	M80	2	M20	1.5	φ760	φ680	φ80
250(10)	673	700	770	632	882	-----	165	55	44	25	245	M90	2	M20	1.5	-----	-----	φ90
300(12)	737	775	819	713	963	-----	178	55	44	28	248	M90	2	M20	1.5	-----	-----	φ90

GYL-20400 Body size

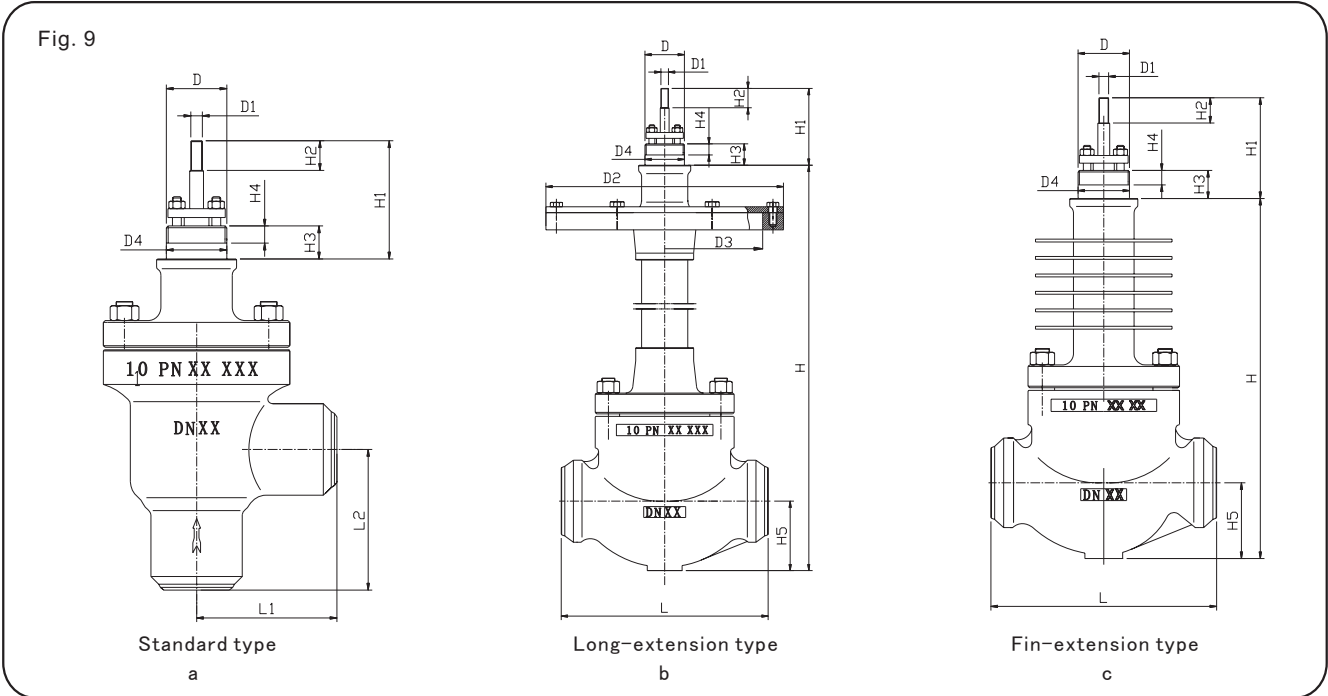

Table. 9

Valve flange execution standard: GB/T 9124-2000

Body size	L			H													D	D1	D2	D3	D4	L1	L2
	ANSI150 PN1.6 JIS10K	ANSI300 PN4.0 JIS30K	ANSI600 PN6.4 JIS40K	Standard type	Fin- extension type	Long- extension type L=800	H1	H2	H3	H4	H5	H1	H2	H3	H4	H5							
20(3/4)	184	194	206	184	334	852	130	40	34	15	52	M56	2	M12	1.25	φ290	φ235	φ56	95	95			
25(1)	184	197	210	184	334	852	130	40	34	15	52	M56	2	M12	1.25	φ290	φ235	φ56	100	100			
40(3/2)	222	235	251	238	407	868	130	40	34	15	68	M56	2	M12	1.25	φ335	φ280	φ56	111	111			
50(2)	254	267	286	262	432	883	130	40	34	15	83	M56	2	M12	1.25	φ370	φ310	φ56	127	127			
65(5/2)	276	292	311	307	507	893	130	45	37	15	93	M68	2	M16	1.5	φ410	φ340	φ68	138	138			
80(3)	298	317	337	319	519	898	130	45	37	15	98	M68	2	M16	1.5	φ440	φ370	φ68	155	155			
100(4)	352	368	394	351	551	917	130	45	37	15	117	M68	2	M16	1.5	φ490	φ420	φ68	175	175			
125(5)	403	425	460	403	660	933	160	50	48	25	133	M80	2	M20	1.5	φ560	φ485	φ80	200	200			
150(6)	451	473	508	444	704	950	160	50	48	25	150	M80	2	M20	1.5	φ630	φ550	φ80	240	240			
200(8)	543	568	610	517	777	986	160	50	48	28	186	M80	2	M20	1.5	φ760	φ680	φ80	300	300			
250(10)	673	700	770	632	882	-----	165	55	44	25	245	M90	2	M20	1.5	-----	-----	φ90	-----	-----			
300(12)	737	775	819	713	963	-----	178	55	44	28	248	M90	2	M20	1.5	-----	-----	φ90	-----	-----			

GYL-20400 Valve matched pneumatic actuator

Fig. 10

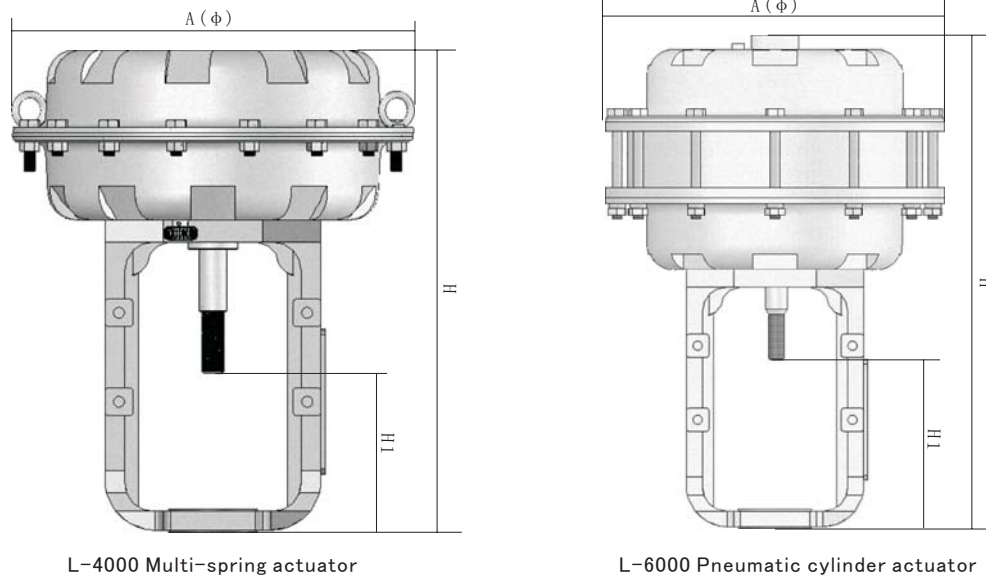

- ◆ L-4000 multi-spring actuator series is a pneumatic diaphragm straight stroke actuator which has light weight, small volume, high performance and big output force.

Table. 10

△=Minimum air supply ▲=Spring pressure range

Actuator	A(φ)	H	Output force(Minimum thrust)			H1	
			△120KPa ▲20-100KPa	△240KPa ▲40-200KPa	△320KPa ▲80-240KPa	Air to open	Air to close
L4020	285	350	628	1286	2512	143	150
L4030	285	370	628	1256	2512	140	162
L4040	360	435	981	1963	3925	141	178
L4050	470	588	1710	3419	6839	172	223
L4060	580	667	2512	5024	10048	175	275

※ Note: The minimal output force is the lowest spring loaded force, equal to spring force when reverse action without air supply or output force when direct action with air supply.

- ◆ The L6000 new type pneumatic cylinder actuator, divides into single action and double action types, the output force is bigger, overall weight is light, the structure is simple, and is easy to disassembles and assembles, maintenance. The air supply is bigger than pneumatic diaphragm actuator, therefore the output force is bigger, thus this series actuator is usually matched to high pressure valve and cut-off valve.

Table. 11

Actuator	A(φ)	H	Output forceN		H1	
			Single action	Double action	Air to open	Air to close
L6030	285	409	3393	14137	140	162
L6040	360	509	6460	26922	141	178
L6050	473	698	11300	47085	172	223
L6060	580	908	17560	73168	175	275

※ Note: the output force on the table is the force when the air supply is 500Kpa, when direct action, the output force of single action is the lowest output force, if the air supply is bigger than 500Kpa, thus the actual output force is bigger also.

GYL-20400 Valve accessory

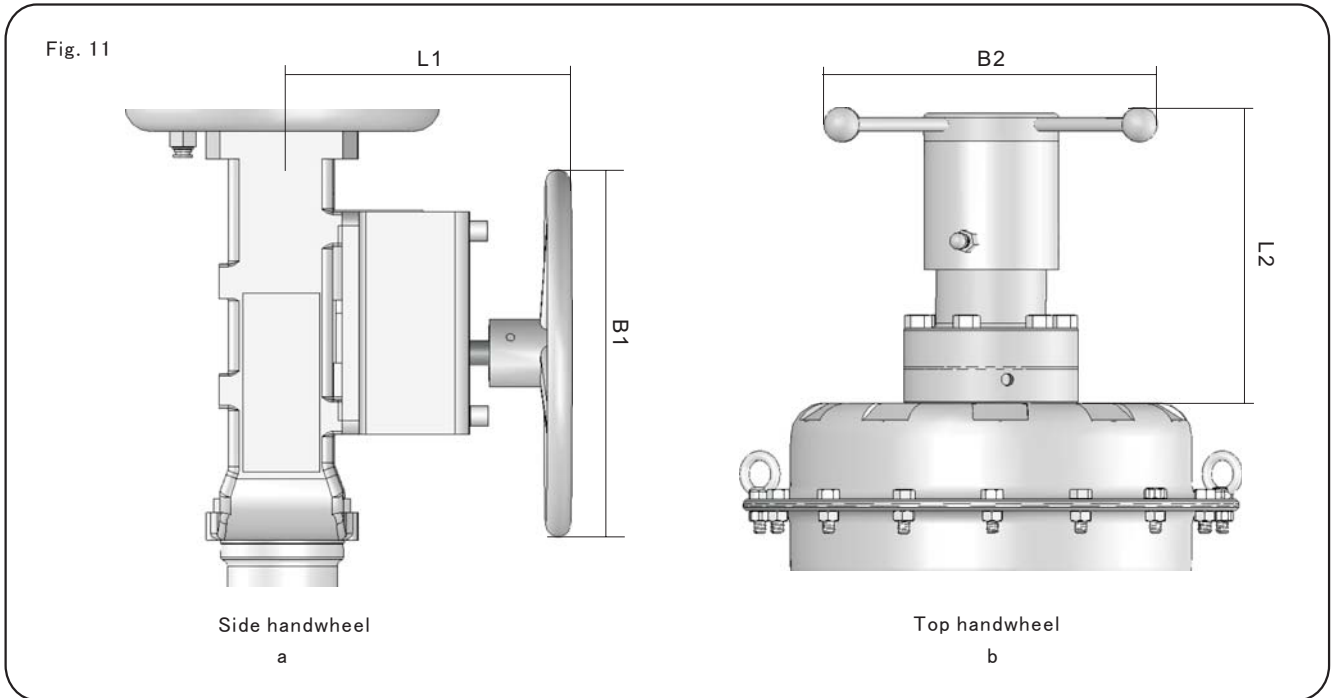

◆ Handwheel

Action: Open or close the valve by handwheel

Type: Side handwheel

Top handwheel

The GYL series control valve may select the handwheel. when stops working either maintenance in the system or the air source and actuator breakdown, we can control the valve by handwheel. Our company has two newest structure handwheel which has good operational ability and is easy to disassemble. Choose top or side handwheel according to installment space and operation custom.

Side handwheel appearance size Table. 12

Actuator	L1	B1 (φ)
L4020-P	135-151	200
L4030-P	135-160	200
L4040-P	138-163	300
L4050-P	158-198	400

Top handwheel appearance size Table. 13

Actuator	B2 (φ)	L2
L4020-D	270	186
L4030-D	270	186
L4040-D	300	215
L4050-D	340	326

BEIER Control Valve

Product Code Model

GY

1	2	3	4	5	6	7	8	9	10	×	11	·	12	·	13	·	14	15	16	17	18
---	---	---	---	---	---	---	---	---	----	---	----	---	----	---	----	---	----	----	----	----	----

Body

Specification

Actuator

1. Code of the valve body

1 CodeNo.	Type	2 CodeNo.	Type	3 CodeNo.	Circulate type	6 CodeNo	Connection type
L	Straight stroke	2	Unbalance trim series	1	Straight structure	1	Flange
		4	Balance trim series	2	Angle structure	2	Wafer
R	Angle stroke	5	Spherical series	3	Three way structure	3	Butt welding End
		7	Butterfly series	4	“z” structure	4	Thread

4 CodeNo.	GYL series trim	GYR series trim	5 CodeNo.	Bonnet type	8 Code No.	Multistage pressure reducing level		
1	Economic type thread screw-in type seat	Eccentric partial spherical	1	Standard	II	II level		
2	High performance type cage embed type seat	Concentric partial spherical	2	Fin-Extension	III	III level		
3	High performance type double plug relief type	Concentric total spherical	3	Long-Extension	IV	IV level		
4	Cut-off type	—	4	Corrugated pipe seal	V	V level		
5	Economic type sleeve double valve seat seat	Normal seal type	5	Clamp cover	VI	VI level		
6	Sleeve single seat	End-face seal type	7 CodeNo.	Trim supplement explanation	VII	VII level		
7	Multi-hole type cage structure	High performance eccentric type			R	Soft seal	VIII	VIII level
8	Labyrinth type cage structure	Triple eccentric multi-layers structure			Y	Metal seal	9 CodeNo. Special request	
9	Multi-stage pressure reducing type	—			S	Seat guided type		
			C	Lining structure type	18 CodeNo. Spring range			
						A	20—100KPa	
						B	40—200KPa	
						C	80—240KPa	
						D	120—360KPa	
						E	160—480KPa	

2. Code of the Specification parameter

10 Code No.	11 Code No.	12 Code No.	13 Code No.	Flow characteristics
Nominal Diameter	Plug size	Nominal pressure	Z	linearity
The code number above may be filled in directly according to the concrete number.			D	Equal-percentage
			X	Special request

3. Code of the actuator

14 CodeNo.	Actuator type	15 CodeNo	Actuator type	17 CodeNo.	Pneumatic type Specification	Piston size	Diaphragm type specification	
L	Straight stroke	4	Multi-Spring diaphragm type	1	Straight stroke	Angle stroke		
		5	Single-Spring diaphragm type					
R	Angle stroke	6	Cylinder type	2	—	65		
		7	Solid state electronic type	3	180	100	2#	
16 CodeNo. Action type			19 CodeNo.	Manual operation	4	—	130	4#
5	Single action Air-open type	P			Side	5	250	160
6	Single action Air-close type	D	Top	6	320	200	6#	
7	Double action with emergency cut-off	W	Worm wheel	7	350	250		
8	Double action with emergency open				8	—	300	
9	Double action				9	—	350	



The marks above are all BEIER's trademark, the others in the book belongs to the other companies.
The layout and product photographs are provided and designed by BEIER company.
The copyright is owned by BEIER, too.
It's forbidden that copy the book by any form or any part without explicit written permission of BEIER.



Top Guided Type Cut-off Control Valve

Domestic Free Consult Tel : 4008110110-801

Zhejiang BEIER Control Valve Co.,Ltd.
Add: XiaoNanShan Industrial district of
TangXia Town,Ruian,Zhejiang China.
Tel: 0086-577-56763781, 56763782
65360522
Fax: 0086-577-65360522
PC: 325204
Email:info@controlvalves.cn
beier@controlvalves.cn
beiercontrolvalve@gmail.com
Web:Http://www.controlvalves.cn